

Local Renewable Power Worldwide



Robust
Silent
Reliable

BEL-v50

The perfect **turbine**
for **trickle charging** batteries

grid-
off



Designed &
manufactured
in the UK

BEL-v50 :Features



BEL-v50

The perfect wind turbine for trickle charging batteries

Features:

Output

12W at 8m/s (17.8mph), 70W max

Silent

Absolutely no noise as the turbine operates

Compact and lightweight

Can be installed in a variety of positions with ease

Cross flow ventilated rotor

Far higher output than similar vertical axis turbines

Robust design

Proven in the severest environment - the Antarctic

Marine quality finish

High quality components and lasting performance

Designed and proven to survive 120mph Antarctic winds

The BEL-v50 fills a gap in the market where small amounts of power are required in harsh environments. This turbine is virtually indestructible having passed the tests of Antarctic winters...

The BEL-v50 delivers power outputs of up to 70 watts in absolute silence. Compared to similar vertical axis turbines, the BEL-v50 delivers far higher output thanks to the cross-ventilated 'savonius' vertical axis rotor. This is coupled with the well proven axial flux alternator design that has been successfully used on all our turbines. With only 1 moving part, there is little to go wrong.

The small footprint and lightweight design allows the turbine to be installed in places where space is a premium. The turbine will receive the wind from 360 degrees without the need to yaw into position. The BEL-v50 can self-regulate without the need for external charge controllers and the turbine's double bearing arrangement is superior to cantilever designs found in other vertical axis turbines.

BEL-v50 : Technical Overview

Rotor diameter:- 270mm

Rotor height:- 456mm

Rotor type:- 3-Blade savonius

Blade material:- Aluminium

Rated output:- 12W at 8m/s (17.8mph)

Peak output:- 70W

Cut-in speed:- 4m/s (9mph)

Weight:- 9Kg

DC Output voltage:- 12V or 24V

Warranty - 2 years

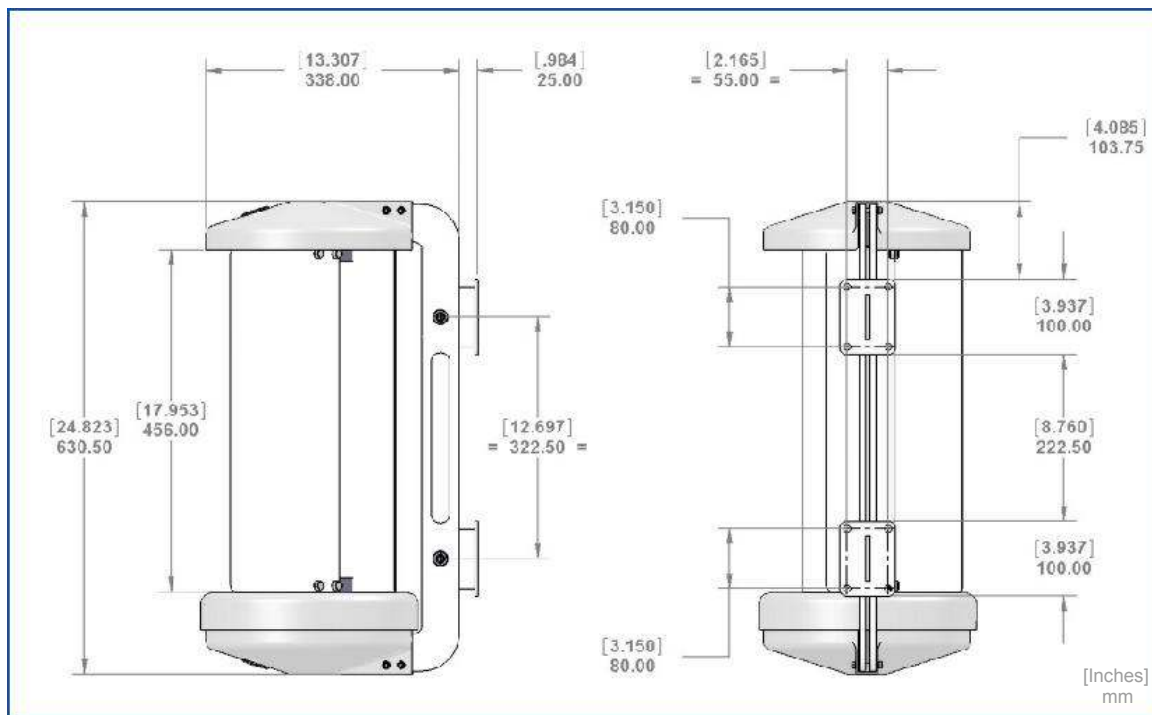
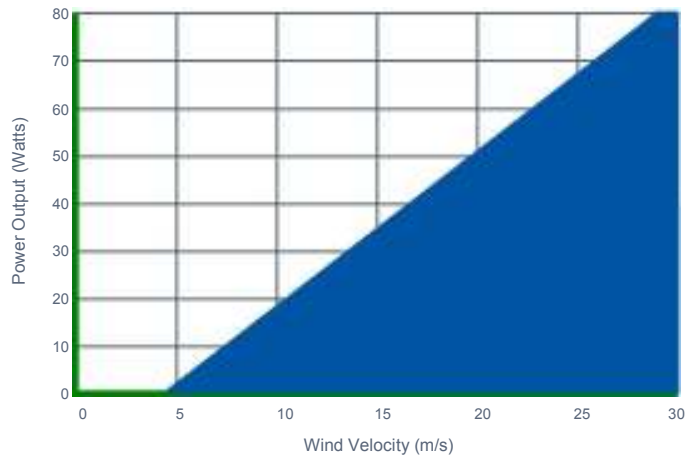

The BEL-v50 has a design life of 20 years, but due to its modular design and ease of maintenance, the turbine could easily run indefinitely.

The BEL-v50 is available in 12V and 24V version and is self regulating. It can be combined with solar PV panels in 'off-grid' renewable energy systems such as powering LED street lights or remote telemetry. The turbine can be mounted from underneath using our Axial mount bracket, or side mounted to an existing structure using the supplied mount brackets.

BEL-v50

:Applications



- Marine
- Telemetry
- Trickle Charging
- LED lighting systems
- Extreme environments
- Off-grid

Wind turbine performance is subject to many factors. All output data contained in this document is indicative and actual turbine outputs will depend on the prevailing site and installation conditions.

Your local distributor

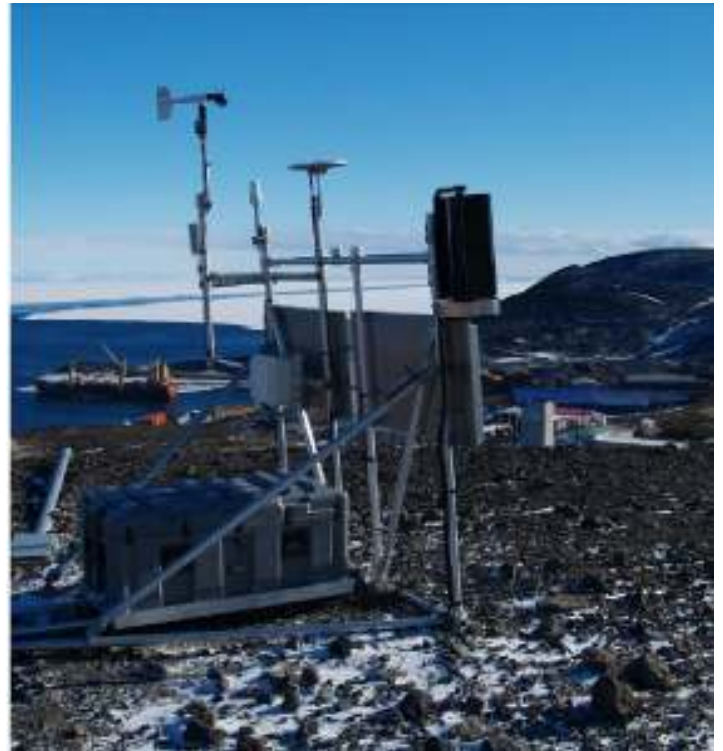

Our BEL-v50 is a compact, silent and lightweight vertical axis turbine. Designed to trickle charge your batteries or provide energy for low power electronic devices such as data-logging or telemetry equipment.

Rominstal Solar

Tel +4021326.81.89 |